

MIR10

Sensor head with magnetic wheel

Max. 4096 pulses per revolution

Overview

- Sensor head with magnetic wheel
- Robust magnetic sensing method
- Max. 4096 pulses per revolution
- Output signals A 90° B with zero pulse
- Output circuits: HTL/push-pull and TTL/RS422
- Non-contact, wear-free sensing system
- High resistance to dirt and vibrations
- Please order magnetic rotor separately



Technical data

Technical data - electrical ratings

Short-circuit proof	Yes
Initializing time	≤ 50 ms after power on (see general informations)
Pulses per revolution	320 ... 4096
Interpolation	10-fold 20-fold 32-fold 64-fold
Output signals	A+, B+, R+, A-, B-, R-
Output stages	HTL/push-pull TTL/RS422
Reference signal	Zero pulse, width 90° (zero pulse only with magnet rotor incl. reference magnet)
Output frequency	≤40 kHz (10-fold interpolation) ≤80 kHz (20-fold interpolation) ≤350 kHz (32-/64-fold interpolation)
System accuracy	Typ. ±0.7° (+20 °C)
Sensing method	Magnetic
Interference immunity	EN 61000-6-2
Emitted interference	EN 61000-6-4
Approval	CE UL

Technical data - electrical ratings (HTL)

Voltage supply	10...30 VDC
Reverse polarity protection	Yes

Technical data - electrical ratings (HTL)

Consumption typ.	20 mA (w/o load)
------------------	------------------

Technical data - electrical ratings (TTL)

Voltage supply	5 VDC ±5 %
Consumption typ.	30 mA (w/o load)
Recommended cable termination	On control side each channel pair 120 Ohm

Technical data - mechanical design

Shaft type	ø6...43.5 mm (through hollow shaft)
Dimensions (sensor head)	10 x 15 x 45.5 mm
Protection EN 60529	IP 66 IP 67
Operating speed	≤10000 rpm (50 and 64 poles) ≤20000 rpm (32 poles)
Working distance	0.1 ... 0.6 mm (axial/radial)
Material	Housing: zinc diecast, plated
Operating temperature	-40...+85 °C
Relative humidity	EN 60068-2-78:2010 EN 60068-2-30:2005 93 % condensation permitted
Resistance	EN 60068-2-6 Vibration 30 g, 10-2000 Hz EN 60068-2-27 Shock 500 g, 6 ms
Weight approx.	130 g
Connection	Cable 2 m Cable 0.3 m with connector M12

MIR10

Sensor head with magnetic wheel
Max. 4096 pulses per revolution

General information

The initializing time of the sensor is 50 ms. Output signals may not be processed during this time.

Terminal assignment

Cable

Core colour	Signals
white	0 V
brown	+Vs
green	A+
yellow	A-
grey	B+
pink	B-
blue	R+ (reference sinal)
red	R- (reference signal inv.)

Cable screen: Screen is connected to sensor housing
Cable data: PUR 4 x 2 x 0.14 mm², shielded
Bending radius: >50 mm (fix) / >100 mm (cable chain)
Outer diameter: 6.3 mm

Cable 0.3 m with connector M12

Pin	Core colour	Signals
1	white	0 V
2	brown	+Vs
3	green	A+
4	yellow	A-
5	grey	B+
6	pink	B-
7	blue	R+ (reference sinal)
8	red	R- (reference signal inv.)

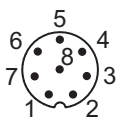

Cable screen: Screen is connected to connector M12 and sensor housing
Cable data: PUR 4 x 2 x 0.14 mm², shielded
Bending radius: >50 mm (fix) / >100 mm (cable chain)
Outer diameter: 6.3 mm

Output signals

With clockwise rotation shown below.

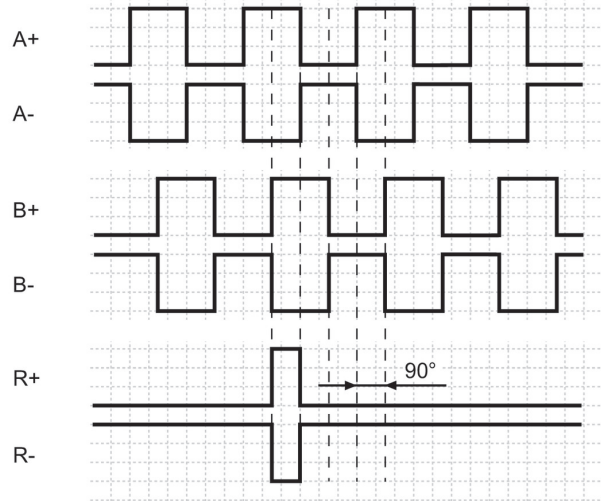

Trigger level

Outputs	HTL/push-pull
Output level High	>+Vs -2.2 V
Output level Low	<0.7 V
Load	≤20 mA

Outputs	TTL/RS422
Output level High	>2.4 V
Output level Low	<0.7 V
Load	≤20 mA

Recommended grounding concept

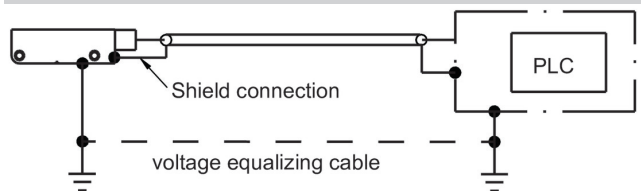

Rotational or linear direction

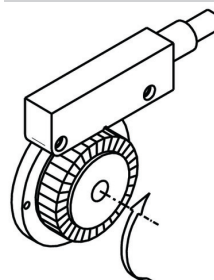

MIR10

Sensor head with magnetic wheel
Max. 4096 pulses per revolution

Axial misalignment

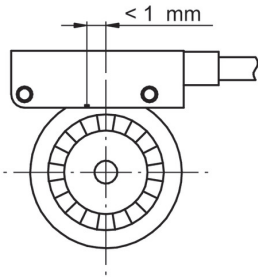

Angular misalignment

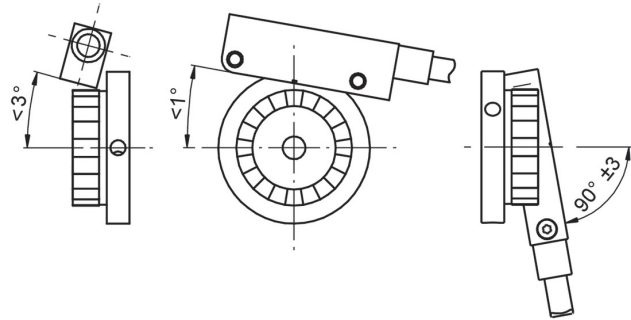

Working distance

MIR10 with reference magnet

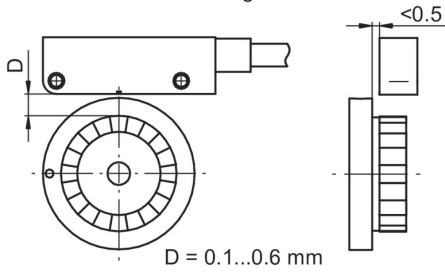

MIR10 without reference magnet

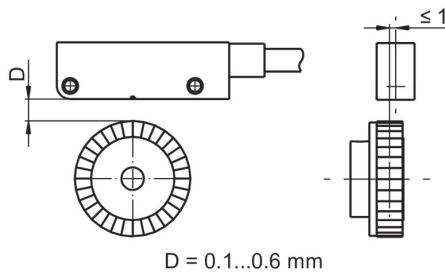

MIR10

Sensor head with magnetic wheel

Max. 4096 pulses per revolution

Dimensions

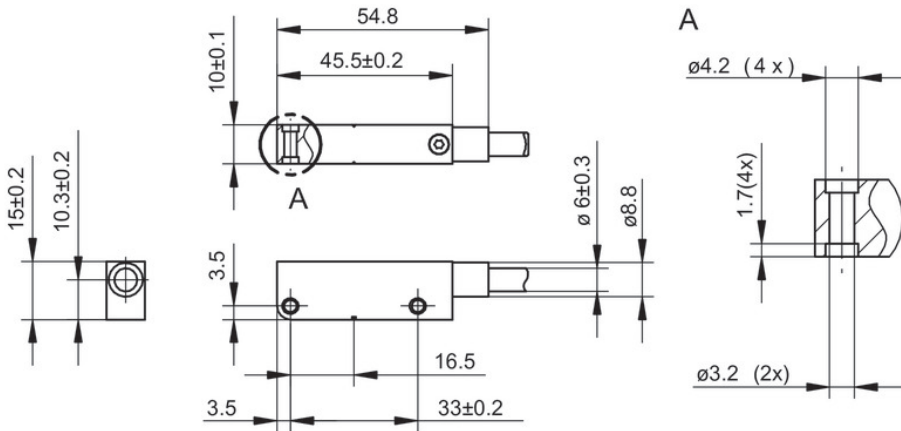

Magnetic wheel with reference magnet

MIR10-P with 32 poles

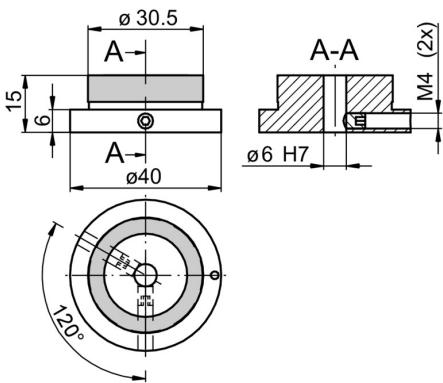

Magnetic wheel without reference magnet

MIR10-P with 32 poles

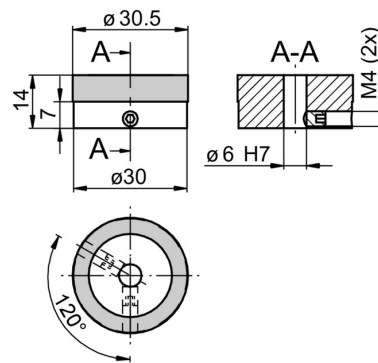

MIR10-P with 50, 64 poles

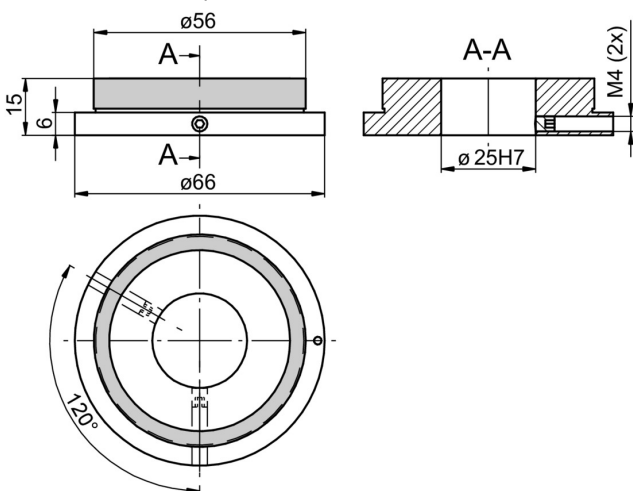

MIR10-P with 50, 64 poles

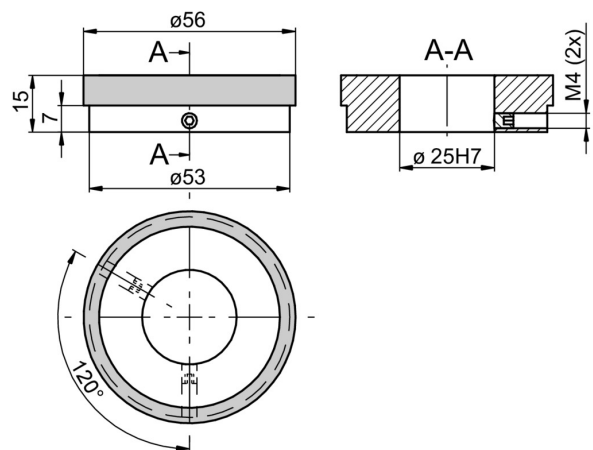

MIR10

Sensor head with magnetic wheel

Max. 4096 pulses per revolution

Ordering reference

MIR10 - S 0 . # # . ### A . A

Product

MIR10

Type

Sensor head

S

Suitable for pole pitch

Variable (incl. 2 mm and 5 mm)

0

Connection

Cable radial, 2 m

L

Female socket M12, 8-poles, after 0.3 m cable

C

Voltage supply / Output

5 VDC ±5 %, TTL/RS422, 6 channel, A+, A-, B+, B-, R+, R-

E

10...30 VDC, HTL/PP, 6 channel, A+, A-, B+, B-, R+, R-

N

Interpolation / resolution

10 pulses per pole

010

20 pulses per pole

020

32 pulses per pole

032

64 pulses per pole

064

Reference signal

Zero pulse via side mounted magnet

A

Operating temperature

-40...+85 °C

A

Part number magnetic wheel

MIR10-P. . S

Bore diameter (Other bore diameter on request)

006 ø6 mm

025 ø25 mm

Reference

N Without reference magnet

A With reference magnet

Number of poles

032.0.031 32 poles (Bore diameter max. 17.5 mm)

050.0.056 50 poles (Bore diameter max. 43.5 mm)

064.0.056 64 poles (Bore diameter max. 43.5 mm)

Selection of sensor head / magnetic wheel

The pulses are a result of the interpolation factor of the sensor head and the number of poles on the magnetic wheel. The table below shows as an example which sensor head and which magnetic wheel have to be combined in order to achieve a certain number of pulses. Other pulses are available on request.

Sensor head MIR10-S	Magnetic wheel MIR10-P		
	32 poles	50 poles	64 poles
Interpolation factor			
10	320	500	640
20	640	1000	1280
32	1024	1600	2048
64	2048	3200	4096